

JH-LQB Submersible Pump Installation, Operation & Service









- Thank you for using Jiahao products!
- Please read this manual carefully before installation and use, and follow the steps described.
- If you have any questions or difficulties, please contact your regional sales company or our company, we will always provide you with quality and fast service.

Wenzhou Jiahao Petroleum Machinery Co. , Ltd.

Dongou Industrial Zone, Oubei Town, Yongjia County, Wenzhou, Zhejiang, China.

1、 Safety precautions

This following safety symbols are used throughout this manual to alert you to important safety hazards and precautions.

	Explosive Fuels and their vapors are extremely explosive if ignited.		Flammable Fuels and their vapors are extremely flammable.
	Electricity High voltage exists in, and is supplied to, the device. A potential shock hazard exists.		Turn power off Live power to a device creates a potential shock hazard. Turn off power to the device and associated accessories when servicing the unit.
	warning Heed the adjacent instructions to avoid equipment damage or personal injury.		Read all related manuals Knowledge of all related procedures before you begin work is important. Read and understand all manuals thoroughly. If you do not understand a procedure, ask someone who does.
	Wear Eye Protection Wear eye protection when working with pressurized fuel lines or epoxy sealant to avoid possible eye injury.		

warning	
    	<p>This product operates in the highly combustible atmosphere of a gasoline storage tank.</p> <p>FAILURE TO COMPLY WITH THE FOLLOWING WARNINGS AND SAFETY PRECAUTIONS COULD CAUSE DAMAGE TO PROPERTY, ENVIRONMENT, RESULTING IN SERIOUS INJURY OR DEATH.</p> <ol style="list-style-type: none"> 1. All installation work must comply with the latest issue of the National Electrical Code (NFPA 70), Code for Motor Fuel Dispensing Facilities and Repair Garages (NFPA) 30A, and any national, state, and local code requirements that apply. 2. Turn off, tag, and lockout power to the STP before connecting or servicing the STP. 3. Before installing pipe threads apply an adequate amount of fresh, UL classified for petroleum, non-setting thread sealant. 4. protect yourself and others from serious injury, death, or substantial property damage, carefully read and follow all warnings and instructions in this manual. 5. When servicing unit use non-sparking tools and use caution when removing or installing equipment to avoid generating a spark.

2、 Warning and instructions

2. 1 Important safety information

This chapter introduces the hazards that may be encountered during installation, inspection, maintenance, and maintenance of this product, as well as the safety measures that should be taken. Before doing anything on this product, please carefully read the safety information and relevant chapters of this manual regarding the hazards and safety measures related to the current work content.

If these safety regulations are not followed, it may cause accidents such as fires, explosions, electric shocks, or pressure splashes, leading to personal injury or even death.

2. 2 Early Prevention

You work in a potentially hazardous environment with high fuel, gas, voltage, and pressure. Only personnel who have received specialized training and obtained certificates can carry out the installation, inspection, maintenance, and upkeep of this equipment.

Carefully read the manual

Read, understand, and comply with this manual and other markings and related materials accompanying this product. If you do not understand the program, request the support of experienced local technicians. Understanding the program before starting work is crucial for your and others' safety. Ensure that your employees and any service personnel read and comply with this manual.

2. 2. 1 Compliance with regulations

All installation work must be carried out in accordance with the latest regulations on electrical installation in hazardous areas (GB/T3836. 15) and the Code for Design and Construction of Gas Filling Stations for Motor Vehicles (GB50156).

All warning information can be found in the regulations of Electrical Installation in Hazardous Areas (GB/T3836. 15) and Design and Construction Specification for Gas Filling Stations in Automobile Gas Stations (GB50156). All these regulations must be followed. Failure to comply with these regulations, rules, and standards during the installation, inspection, maintenance, and upkeep of this product may result in legal penalties or affect the safe use and operation of the equipment.

2. 2. 2 Prevention of explosions and fires

Oil and its gases will explode or burn in the event of an open flame. The overflow or leakage of oil can evaporate into oil vapor. Even refueling a customer's oil tank near a refueling machine or refueling island can generate potential hazardous gases.

2. 2. 3 Working alone

It is strongly recommended to have the ability to implement first aid during service. If you work in a high-pressure environment, you need to master the methods of cardiopulmonary resuscitation. When working on this device, be sure to inform the gas station personnel where you are working and remind them not to turn on the power. Lock and tag out according to the instructions. If you are not familiar with this device, please refer to the relevant documentation in the manual.

2. 2. 4 Electrical safety work

Ensure that you use safe and specialized electrical tools. Improper wiring tools can cause fire, explosion, or electric shock. Ensure that the ground wire is connected correctly. Ensure that the wires are not pressed down when covering the lid. Lock and tag out according to the instructions. When the equipment loses power, gas station employees and service personnel need to understand and fully comply with this procedure to ensure safety. Before you start working, you need to know the position of the emergency power off switch (E-STOP). This switch is only used in emergency situations and can disconnect the power supply of refueling equipment and submersible pumps. The button is located at the cash register, do not turn off the power supply of the submersible pump refueling machine. This means that if you press the emergency power off, all power off, submersible pump power off, or other similar buttons, the oil will flow out uncontrollably.

2. 2. 5 Hazardous Materials

Some materials can pose a health hazard if handled improperly. After handling, be sure to wash your hands immediately. Do not put any equipment in your mouth.

Warning! Failure to follow all instructions according to the correct rules will result in personal injury or death.

Fire! It is strictly prohibited to use electric tools when installing or maintaining equipment. Electric sparks can ignite oil or its gases, which can cause a fire.

Chemical exposure hazard! Wear appropriate protective equipment when installing or maintaining equipment. Avoid contact with oil and gas. Long term exposure to oil can cause serious skin pain, and in severe cases, burns,

2. 3 Service conditions

The submersible pump is only designed and used for automotive fuel refueling equipment.

The application of submersible oil pumps must comply with the requirements of electrical installation in hazardous areas (GB/T3836. 15) and the Code for Design and Construction of Gas Filling Stations in Automobile Gas Stations (GB50156).

The selection of any Jiahao product must be based on its physical specifications, limitations, and compatibility with the processed materials of the product. Jiahao does not provide warranty for special use.

All Jiahao products must be used in situations that comply with national and gas station regulations.

2. 4 Preventive Measures

No Smoking. Turn off all open flames and permanent lights.

Turn off mobile phones and other electronic devices to prevent interference with refueling.

Swallowing gasoline is harmful to the body and even fatal. Long term exposure can cause cancer. Do not come into contact with oil and gas in the eyes and skin. Avoid prolonged exhalation of oil and gas.

2.5 Oil Compatibility

The working gas environment of the submersible pump is Class 1 gas in Group D and complies with GB/T3836.1, GB/T3836.2, GB/T3836.9, IEC60079-33-2012 standards, as well as the European 94/9/EC "Equipment with Potential Explosive Hazards" (II 2G Ex IIA T4) directive. The production and manufacturing of the product comply with the requirements of the enterprise standard Q/WJH 16-2022.

2.6 Requirements for conveying medium:

- 1) Suitable for non corrosive IIA and IIB grade oil or liquid media, with a density not exceeding 1.0g/cm³, a viscosity not exceeding 1.2mm²/s, and a pH value of 6.5-8.5.
- 2) Transmission medium temperature: -25°C ~+55°C .
- 3) The conveying medium does not contain solid impurities, such as sediment, iron filings, etc.

All models of Jiahao submersible pumps have passed explosion-proof certification and can use the following fuels						
Diesel	Gasoline	Gasoline with the following upper limit content fuel				
		15% Ethanol	15% Methanol	20% MTBE	20% ETBE	20% TAME

The Standard STP is designed to be compatible with 100% gasoline, or diesel and 80% gasoline with 20% methanol, ethanol, TAME, ETBE, or MTBE. The density of the conveying medium is not more than 0.95x 103 kg/m³.

The kinematic viscosity of the conveying medium (at 159C) is not greater than 13x10⁻⁶ mm²/s (or 70SSU).

The Quick-Set feature is an adjustable column pipe and electrical conduit that allows the overall length to be adjusted to a wide range of overall pump lengths. By loosening a collet on the column pipe, the length of the pump may be varied by extending or retracting the column Pipe.

Four Quick-Set sizes are available, covering most pump length requirements, for precise lengths, see the sizing charts within this chapter.

3. Manifold Dimension

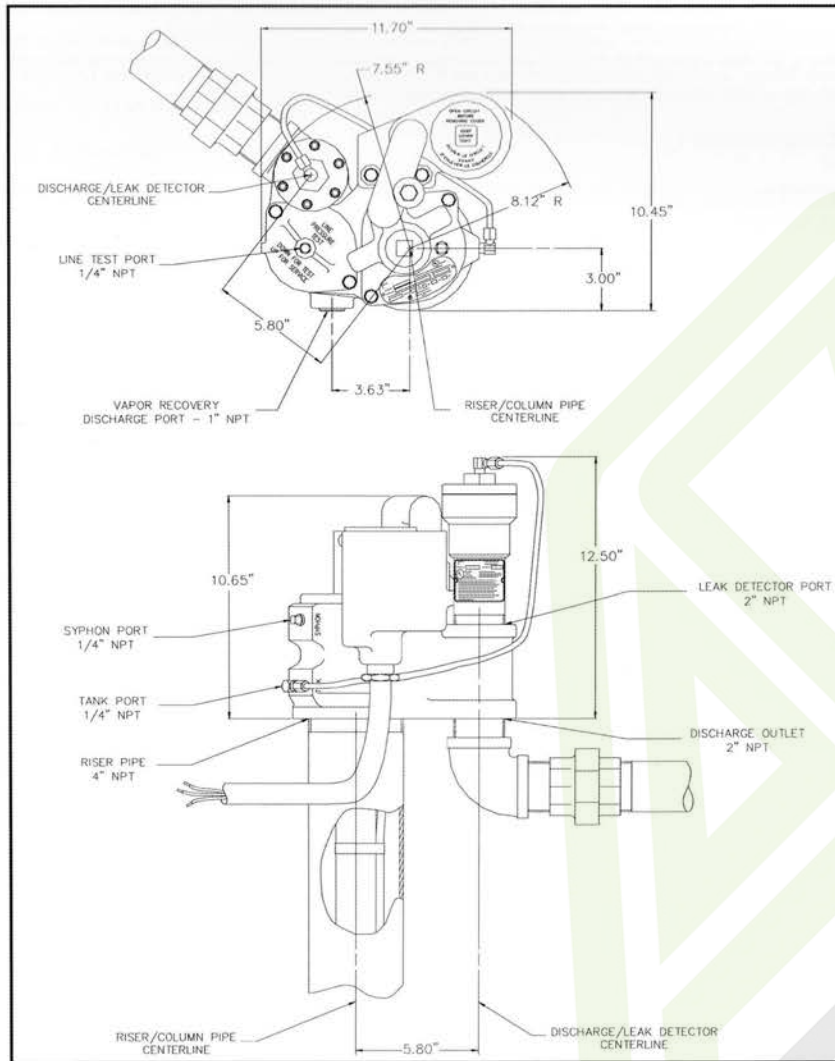
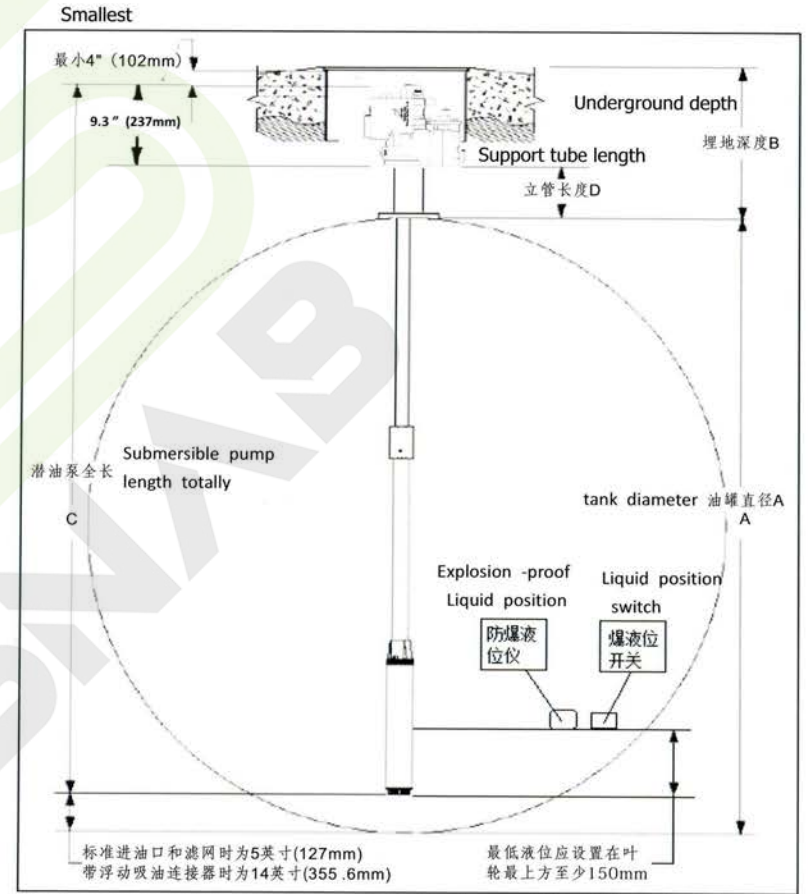

Figure 1. Manifold Dimensions

4. Dimensions for Pump Selection

Figure 2 shows the dimensions needed to ensure a correctly sized pump.



With the standard oil inlet and filter are 5-inch (127mm)
 With a floating oil-absorbing connector is 14 inches (355.6mm)
 The minimum liquid level should be set at least 150mm above the bottom of the motor

Figure 2. Measuring the tank (see Table 2 for adjustment ranges).

NOTE: 1. The submersible pump is a centrifugal pump, so when the oil level is lower than the bottom of the pump motor component, the submersible pump cannot extract the oil.

2. Distance between centerline of pump motor and centerline of bottom fill tube should be 3 feet (914mm) minimum. Air locking of pump after product delivery may occur at distances less than this.
3. The minimum liquid level should be set at least 150mm above the bottom of the motor
4. Submarine pumps must be installed with two different measurement principles of explosion-proof liquid position or explosion-proof liquid level switch. The equipment protection level (EPL) of the explosion-proof liquid position and explosion-proof liquid level switch must be GA, and the control circuit locks with the submarine pump to achieve the double stop level protection of the submarine pump.

5. Model specifications and main technical parameters

5.1 Model specifications

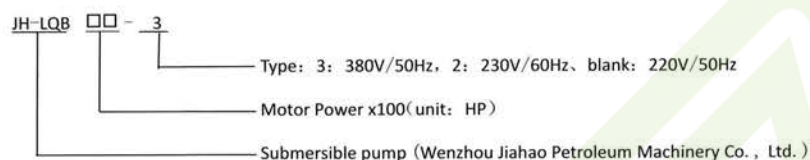

5.2 Main technical parameters

Table 1 shows the adjustable pump lengths by model

Table 1: Distance

Item Code	Telescope	Length Mm	Flow Rate (L/Min)	Work Pressure (Mpa)	Theory Head	Suite For Nozzle Qty	Noted
JH-LQB75-□	T1	1854~2540	200±10%	≤0.20	27m	1~4	“□” : Power Parameter “Blank” : 220V/50Hz “2” : 230V/60Hz “3” : 380V/50Hz
	T2	2438~3302					
	T3	3302~5004					
	T4	3302~4166					
JH-LQB150-□	T1	1905~2591	250±10%	≤0.25	33m	4~6	
	T2	2489~3353					
	T3	3353~5055					
	T4	3353~4216					
JH-LQB200-□	T1	1956~2642	300±10%	≤0.30	40	6~8	
	T2	2540~3404					
	T3	3404~5105					

The length of the range is the distance from the lifting ring to the oil inlet.

5.5.2 various types of Submarine pumps head- flow rate curve diagram

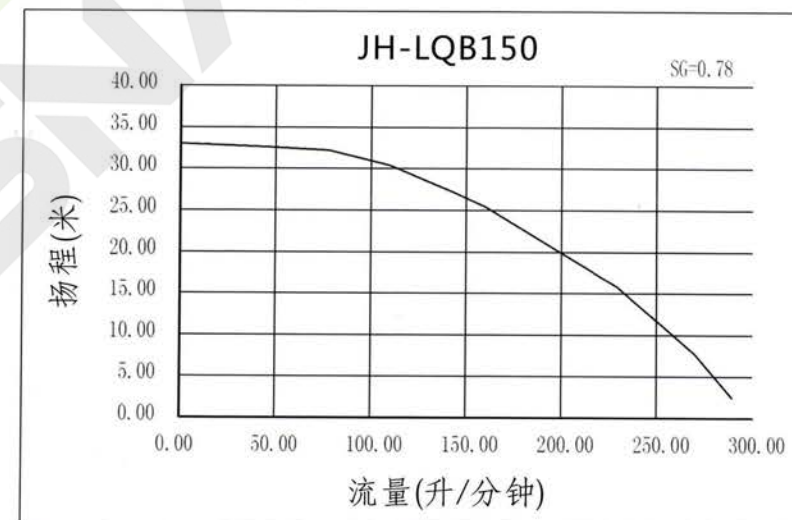
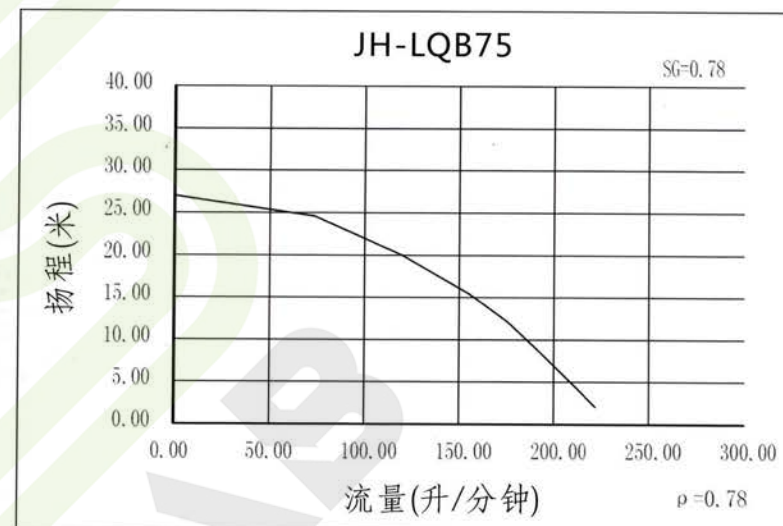

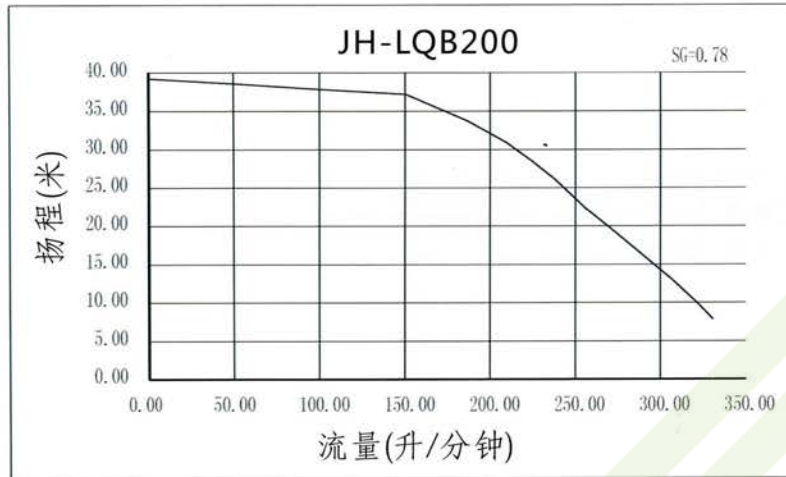

Table 2 : Electrical Tech Information

Model No.	Voltage V	Hz	HP	Efficiency %	Rate Speed r/min	Power factor	Insulation level	Blocking / rated torque N*m	Rated current A	Blocking /rated current A
JH-FSP75	220	50	0.75	≥69	2850	0.90	B	0.5	6	5
JH-FSP75-2	230	60	0.75	≥69	3420	0.95	B	0.5	5	5
JH-FSP75-3	380	50	0.75	≥69	2850	0.82	B	1.2	3	7
JH-FSP150	220	50	1.5	≥69	2850	0.9	B	0.5	9.5	5
JH-FSP150-2	230	60	1.5	≥69	3420	0.96	B	0.5	8.0	5
JH-FSP150-3	380	50	1.5	≥69	2850	0.82	B	1.2	3.5	7
JH-FSP200	220	50	2	≥69	2850	0.92	B	0.5	12	5
JH-FSP200-2	230	60	2	≥69	3420	0.95	B	0.5	10	5
JH-FSP200-3	380	50	2	≥69	2850	0.82	B	1.2	4.1	7

Table 3 JH-FSP weights and lengths.

FSP Model	HP	Length		Weight	
		in	mm	lb	kg
JH-FSP75	0.75	19 7/8	505	28	12.7
JH-FSP75-2	0.75	19 7/8	505	28	12.7
JH-FSP75-3	0.75	19 7/8	505	28	12.7
JH-FSP150	1.5	20 1/2	522	31	14.1
JH-FSP150-2	1.5	20 1/2	522	31	14.1
JH-FSP150-3	1.5	22 5/8	575	34	15.5
JH-FSP200	2	26	660	37.5	17
JH-FSP200-2	2	26	660	37.5	17
JH-FSP200-3	2	26	660	37.5	17

Note: The weights and lengths listed in the above table are approximate values and may vary with manufacturing tolerances.

5.3 Working environment conditions:

- a. Normal working environment temperature: -25 °C~55°C;
- b. Relative humidity: 30%~90%;
- c. Atmospheric pressure: 80KPa~110KPa;
- d. The pump motor part can be used in explosive gas environments in Zone 0 locations; The pump head can be used in Zone 1 locations in explosive gas environments. Explosive gas or vapor mixtures of Class IIA and IIB T1 to T4.
- e. In areas without significant shaking and shock vibrations;
- f. In an environment without damaging insulation gases or vapors;
- g. The working system of the submersible pump is S1

6、 Installation

6.1 Installation and maintenance precautions:

- 1) The internal grounding should be reliably connected to the internal grounding screw through the power supply PE wire, and there should be anti loosening and anti-corrosion measures; The external grounding of the equipment should be reliably connected to the on-site grounding pile through a yellow green grounding wire of no less than 4mm².

- 2) The installation and use of submersible oil pumps must comply with the requirements of GB/T 3836. 15-2017 "Explosive Atmospheres – Part 15: Design, Selection and Installation of Electrical Equipment".
- 3) The inspection and maintenance of submersible oil pumps must comply with the requirements of GB/T 3836. 16-2017 "Explosive Atmospheres – Part 16: Inspection and Maintenance of Electrical Equipment".
- 4) The maintenance of submersible oil pumps must comply with the requirements of GB 3836. 13-2013 "Explosive Atmospheres – Part 13: Equipment Repair, Maintenance, Repair, and Transformation".
- 5) The operators of the product should undergo explosion-proof training.

6.2 Attaching the FSP

Table 4 Lists the applicable FSPs for each manifold

Table 4 Applicable FSPs for 4"Standard Manifold

Model	Manifold	FSP
JH-LQB75	JH-P	JH-FSP75: 0.75HP/220V/50Hz (0.55kW)
JH-LQB75-2		JH-FSP75-2: 0.75HP/230V/60Hz (0.55kW)
JH-LQB75-3		JH-FSP75-3: 0.75HP/380V/50Hz (0.55kW)
JH-LQB150		JH-FSP150: 1.5HP/220V/50Hz (1.1kW)
JH-LQB150-2		JH-FSP150-2: 1.5HP/230V/60Hz (1.1kW)
JH-LQB150-3		JH-FSP150-3: 1.5HP/380V/50Hz (1.1kW)
JH-LQB200		JH-FSP200: 2HP/220V/50Hz (1.5kW)
JH-LQB200-2		JH-FSP200-2: 2HP/230V/60Hz (1.5kW)
JH-LQB200-3		JH-FSP200-3: 2HP/380V/50Hz (1.5kW)

The FSP is identified by the model number marked on the shell. The manifold assembly with attached piping is identified by the catalog number on the capacitor cover nameplate. The catalog number will be followed by T1, T2, T3, or T4 on adjustable length pumps.

The attachment hardware kit to be used to connect the FSP to the Manifold assembly piping consists of four M8 socket head cap screws, four 8 spring lock washers and one discharge head gasket. (See Figure 3)

NOTE: suggested tools (non-sparking) include a 3/4" wrench, pipe wrench, 1/4" allen wrench, 9/16" wrench, screw driver, wire cutter and wire stripper.

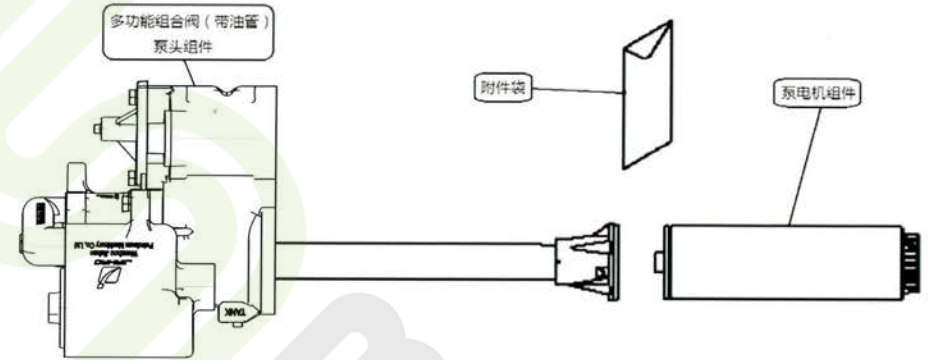

Figure 3: Manifold with piping attaching to FSP

1. Place the new gasket on the new FSP so that all holes align. Gaskets from competitive FSPs will not seal properly and performance will be reduced. CAUTION: Visually inspect the pigtail connector in the discharge head. Replace if damaged. Be certain the indexing tab of the pigtail is seated in the notch of the discharge head.

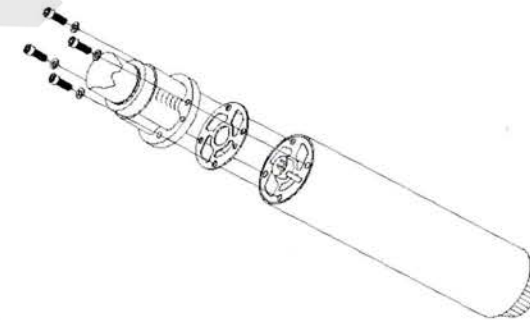

Figure 4: Aligning the FSP gasket

2. Lubricate the O-ring and pigtail with petroleum based jelly.
3. Align the FSP positioning dowel and four screw holes with the proper holes in the discharge head and push the FSP into position using hand force only (see Figure 5). The FSP should be snug against the discharge head prior to installing the FSP retaining bolts.

NOTE: Use hand force to put the FSP onto the discharge head. If the FSP does not seat snug against the discharge head, remove the FSP and correct the problem.

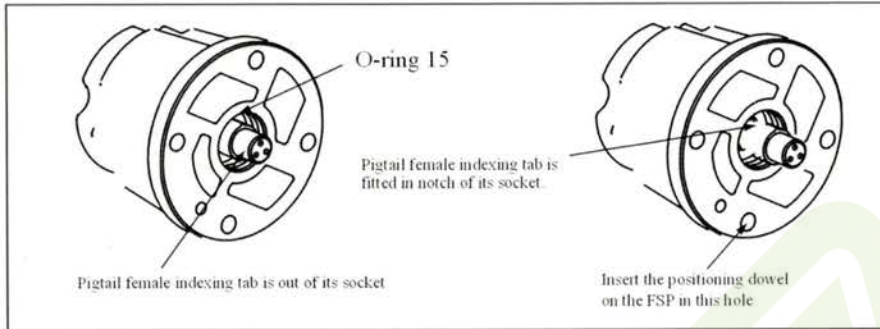

Figure 5: Verifying Pigtail's Female Connector Is Seated Properly

4. Install the FSP retaining bolts and lock washers (see Figure 4). Snug and then torque the bolts using a cross pattern. Torque to 7 f-lb. (11N*m)

NOTE: Do not use the bolts to pull the FSP into position. Use the cross pattern to snug and torque bolts. Do not over torque the bolts.

6.3 Installing the Pump

When servicing equipment, use non-sparking tools and use caution when removing or installing equipment to avoid generating a spark.

NOTE:

- JIA HAO petroleum pumps are designed to operate in a Class II, Group B atmosphere
- The manufacturer may recommend new specifications and installation instructions.
- The product temperature must not exceed 105 F (41C) because the thermal overload protectors in the submersible motors may trip.

1. Install the riser pipe into the 4" tank opening. Apply an adequate amount of fresh, non-setting thread sealant. Tighten the riser pipe in the tank until watertight.
2. Measure the distance from the bottom of the tank to the top of the 4" riser pipe as shown in Figure 6. Confirm the installed length of the pump maintains adequate clearance from the pump inlet to the bottom of the tank (see Figure 2).

FOR FIXED LENGTH PUMPS, SKIP STEPS 3-6 AND THEN FOLLOW STEPS 7-10.

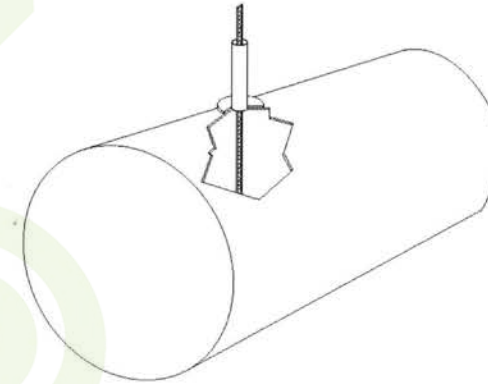

Figure 6: Measuring tank

3. Uncoil the pigtail and lay it flat so it will feed into the wire conduit without knotting or kinking
4. Loosen the clinch assembly starting by unscrewing the set screw in the side of locking nut, then backing off the locking nut (see Figure 7).

NOTE: A slight twisting of the FSP will loosen the seals and facilitate adjusting it to the correct length.

WARNING! Do not rotate piping beyond 1/4 turn.

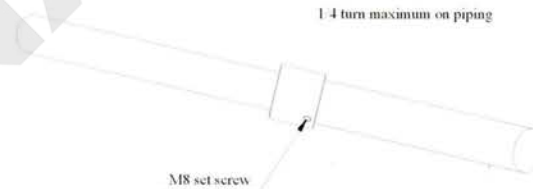

Figure 7: Loosening Locking Nut

5. Referencing Figure 8, pull the FSP end until the distance between the bottom of the manifold and the bottom of the FSP is 8 inches (200 mm) (14 inches [356 mm] for floating suction) shorter than the distance measured in Step 2.

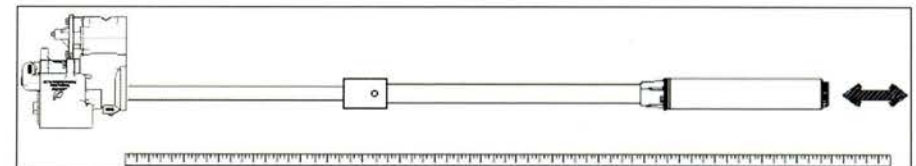

Figure 8: Adjusting pump length

NOTE: Take care not to damage the pigtail. If pump is to be adjusted shorter, tension must be kept on pigtail to eliminate kinking.

6. Tighten the column pipe locking nut and torque to 150 ft-lb. (200 N·m) minimum. then torque the setup screw in the locking nut to 30–35 in. lb. (35–4N*m).

NOTE: Return line should be installed on every application to reduce nuisance trips of electronic tank monitoring.

7. Attach tubing to barbed fitting, secure with clamp.

8. Lay the tubing beside the column pipe. Stop 1–3 inches (25–76 mm) above the discharge head.

9. Secure the siphon return line tube to the column pipe with tie straps. Locate the tie straps approximately 6 inches (152 mm) from the manifold. 6 inches from the discharge head and in the middle of the tubing (see Figure 9).

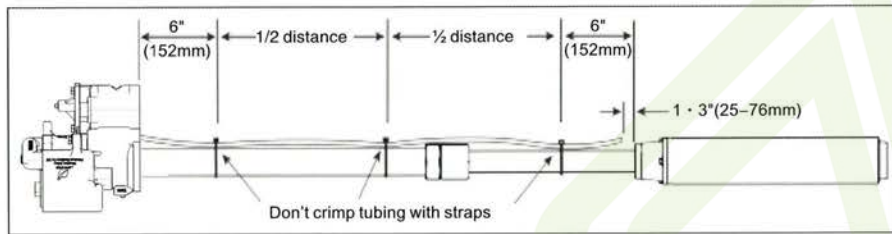

Figure 9: Attaching Return Line Tubing To Pump

10. Apply an adequate amount of fresh, non-setting thread sealant to the threads of the riser pipe.

11. Remove cover from wiring compartment.

12. Pull pigtail wires into wiring compartment.

13. Cut pigtail wires leaving approximately 8 inches (200 mm) hanging out of wiring compartment.

14. Strip insulation off all wires 3/8 inch (10 mm).

15. Using supplied wire nuts, attach like colored pump pigtail wires to like colored electrical connector wires as shown in Figure 10.

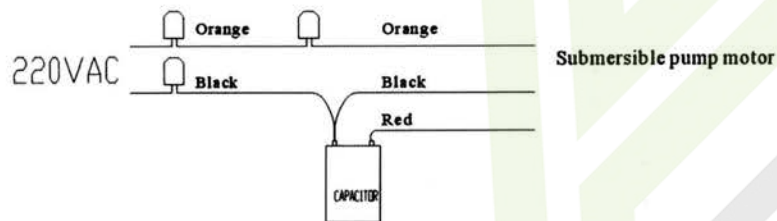

Figure 10: Capacitor wiring schematic

16. Put the wire in the wiring box, twist the wiring box cover, and the tightening torque is 37 pounds · feet (50 Newton · mm). No need to apply thread tightly sealing glue

7. Conduit Box Wiring

DANGER! Always disconnect, lock out, and tag the power before starting to service the pump.

1. Connect electrical conduit approved fittings to conduit box.

2. Remove cover from conduit box.

3. Connect wires from power supply to wires in the conduit box. Install ground wire from power panel (see Figure 12) as shown. Thread sealant required on single box.

4. For Dual Box: Inspect o-rings on access covers, replace if necessary. Lubricate O-ring with petroleum based jelly. Reinstall access covers. Torque 37 ft-lb (50 N*m). Do not use thread sealant on dual box.

5. For Single Box: Apply an adequate amount of fresh, UL classified for petroleum, setting thread sealant to the 2" NPT plug and torque until watertight.

7.1 For Three Phase Pumps (Without Capacitor)

See following figure for steps 1 through 4.

1. Connect the orange wire from the manifold's female connector to M1 from the output of the control box.

2. Connect the black wire from the manifold's female connector to M2 from the output of the control box.

3. Connect the red wire from the manifold's female connector to M3 from the output of the control box.

4. Connect the ground wire from the power panel to the ground screw in the conduit box.

5. For Dual Box: Inspect O-rings on access covers, replace if necessary. Lubricate O-ring with petroleum based jelly. Reinstall access covers.

6. Torque 37 ft-lb (50 N·m). Do not use thread sealant on dual box.

7. For Single Box: Apply an adequate amount of fresh, UL classified for petroleum, setting thread sealant to the 2" NPT plug and torque until watertight.

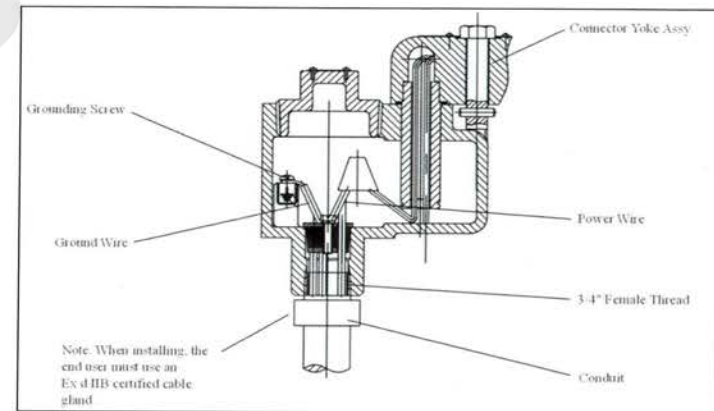

Figure 11: Conduit Wiring

7.2 Installing Two Pumps for Tandem Operation

When greater flow rates are needed, two pumps may be installed in the same piping system by means of a manifold. If installed according to the Figure 21, tandem systems offer backup support so operation can continue if one pump stops working.

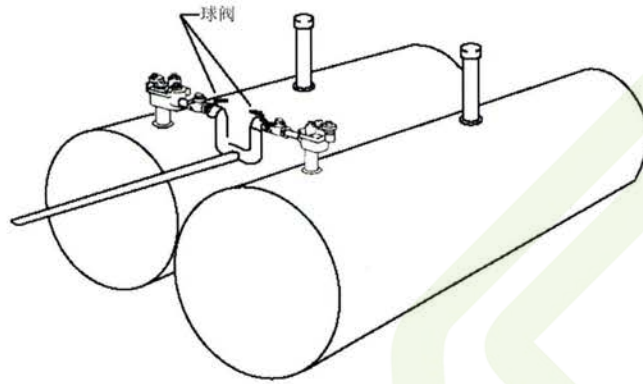

Figure 13 Tandem pumps

WARNING! Element on both packers to maximum relief pressure by rotating fully clockwise. If maximum pump pressures are not a minimum of 5 psi (34KPa) below the functional Element relief setting then proper check valves with pressure relief are required to be installed in the discharge line of each pump to prevent product from being pumped through the pressure relief system of the adjacent pump when it is operation.

NOTE: Ball valve should be installed at the pump end or the discharge line for ease of maintenance and troubleshooting (see Figure 13).



图 13 380V 三相控制柜接线实例

8. Initial Start Up of Pump

Turn on the pump and purge the system of air by pumping at least 15 gallons (57 liters) through each dispenser. Begin with the dispenser furthest from the pump and work toward the pump.

Pump start up is now complete.

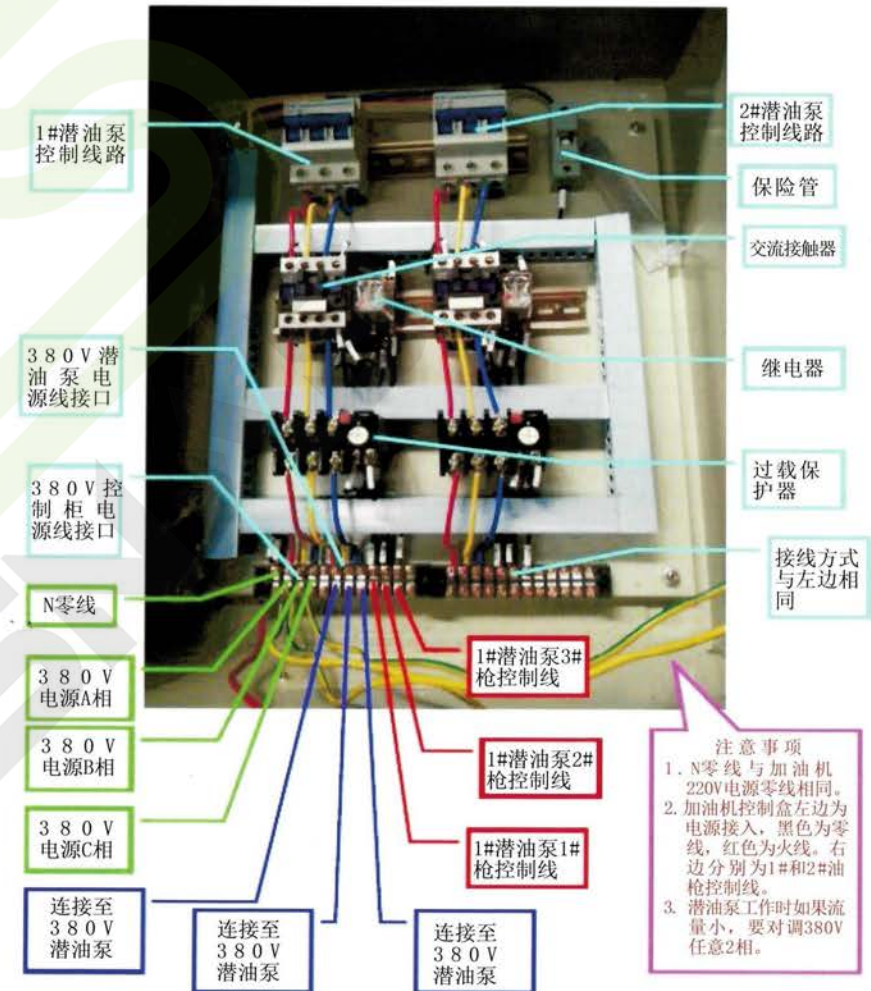
Note: For Three Phase Pump Only

Where it is not convenient to predetermine the power supply phase rotation, the proper rotation can be determined by pump performance. The pump head pressure and capacity will be considerably less than rated when rotating backwards.

Connect the pump leads to terminals T1, T2, and T3 of the magnetic starter observing the color code shown in Figure A, B, and C. With ample product in the tank and the system purged of air, start the pump and make a pressure gauge reading of the system pressure with the ball valve closed, or, open valve and calculate the pumping rate.

L1, L2 Next, reverse power leads at L1 and L2. Repeat either the pressure or capacity test, as described above. If the results are higher than the first test, the rotation of the second test is correct. If the second test gives lower performance than the first, reconnect the power leads to L1 and L2 for the correct rotation.

Where the power supply has been properly marked L1, L2 and L3 in accordance with the accepted phase rotation standards, it is possible to predetermine the proper rotation of these units. The pump power leads are color coded orange, black, and red, and if connected through the magnetic starter to L1, L2 and L3 respectively, the FSP will rotate in the correct direction. It is recommended, however, that the performance tests always be made whether or not the power supply has been properly phased.

9. Testing The Installation

DANGER! Always disconnect, lock out, and tag the power before starting to service the pump.

When service unit use non sparking tools and use caution when removing or installing equipment to avoid generating a spark.

9.1 To Test Piping

1. Block lines at each dispenser. (Trip dispenser shear valve.) Remove line test plug for this test.
2. Remove protective plug and close pump check valve by turning the vent closing screw clockwise as far down as possible. (See Figure 15)

CAUTION: Excessive pressure (above normal test pressure of 50 – 55 psi (345-380 kPa) may damage check valve seat and other system components.

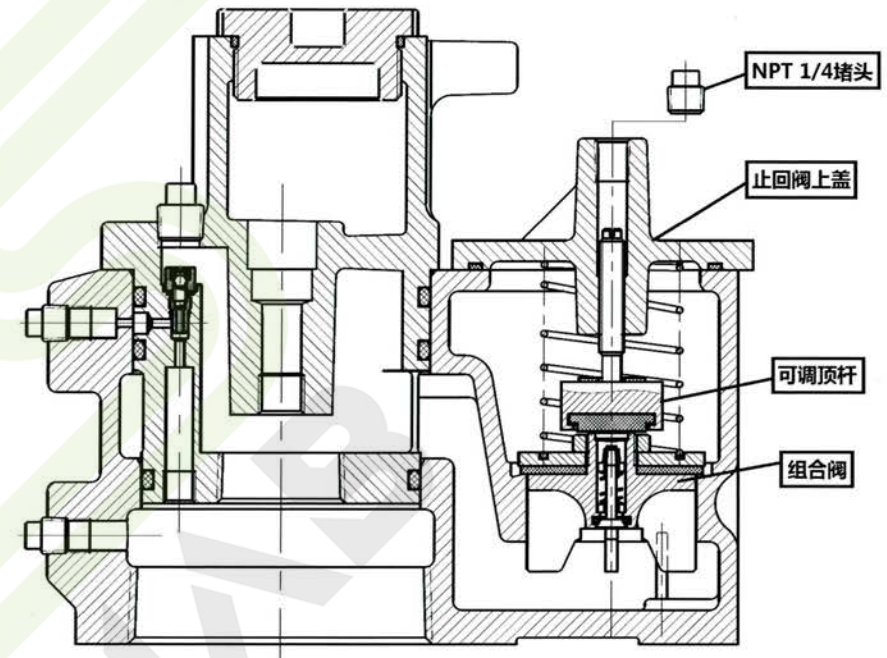

Figure 15 Closing the check valve

3. Remove the pipeline pressure after the test is completed. Continue to keep the combined valve closed.

9.2 Test Tank

DANGER! Always disconnect, lock out, and tag the power before starting to service the pump

When service unit use non sparking tools and use caution when removing or installing equipment to avoid generating a spark.

1. Remove the protective plug and close pump check valve by turning the vent closing screw (see Figure 15) as far down as possible. Remove the 1/4" NPT tank test port plug and attach tank testing equipment. Apply tank test pressure at tank test port.
2. After completion of tank tests, depressurize tank and remove testing equipment. Apply an adequate amount of fresh, UL classified for petroleum, non-setting thread sealant on the 1/4" NPT plug and replace it in the tank test port. Torque the plug to 14 to 21 ft-lbs (19.4-29N.m)
3. After the installation is completed and tests have been made, purge system of air by pumping at least 15 gallon (57litrs) through each dispenser. Begin with the dispenser furthest from the pump and work toward the pump

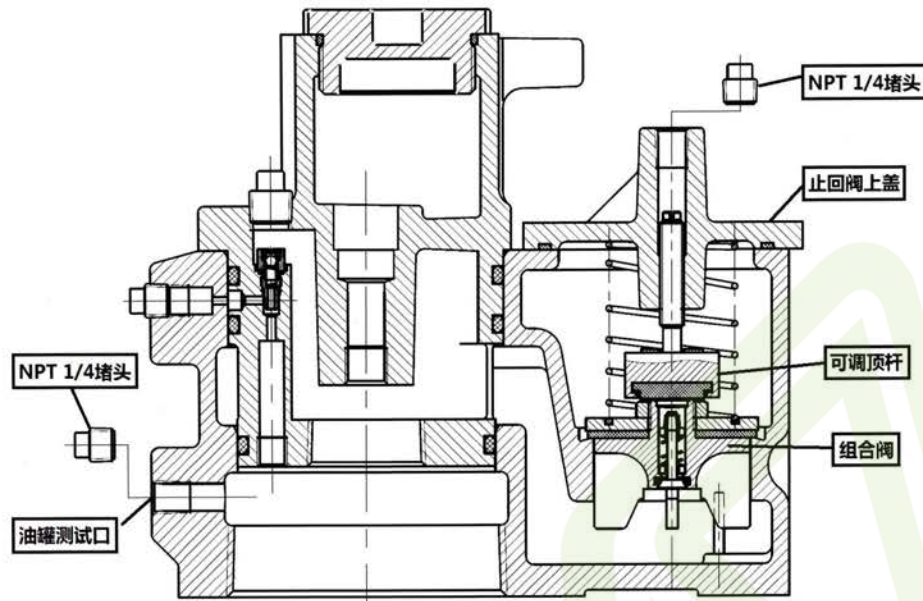

Figure 16 Close the combination valve

10. Service And Repair

10. 1 Removing the Pump

DANGER! Always disconnect, lock out, and tag the power before starting to service the pump.

When service unit use non-sparking tools and use caution when removing or installing equipment to avoid generating a spark.

1. If ball valve is installed down line from the pump, close it.
- 2 Back our the electrical yoke disconnect bolt (see Figure 17)

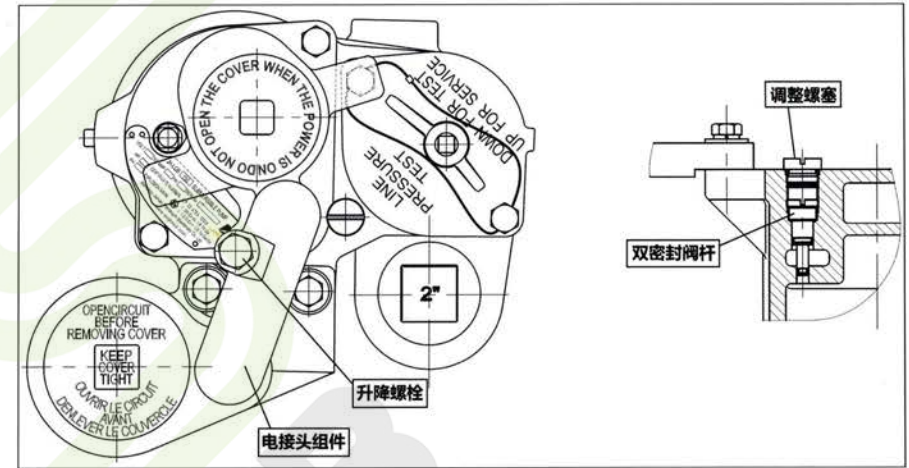

Figure 17 Manifold

3. Swing the electrical connector aside
4. If a siphon system is in place, disconnect the siphon tubing. If ball valve are installed, close them
5. Remove the two lock-down bolts. To relieve pressure, rock the pump to allow excess pressure to flow into the tanker or back our Functional Element screw.

10. 2 Replacing the FSP

DANGER! Always disconnect, lock out, and tag the power before starting to ser vice the pump.

When service unit use non-sparking tools and use caution when removing or installing equipment to avoid gener ating a spark.

1. Remove the extractable portion of the old pump from the tank as desa ibed in Removing the Pump.
2. Remove the old FSP by removing the four bolts holding the discharge head as shown in Figure 18.

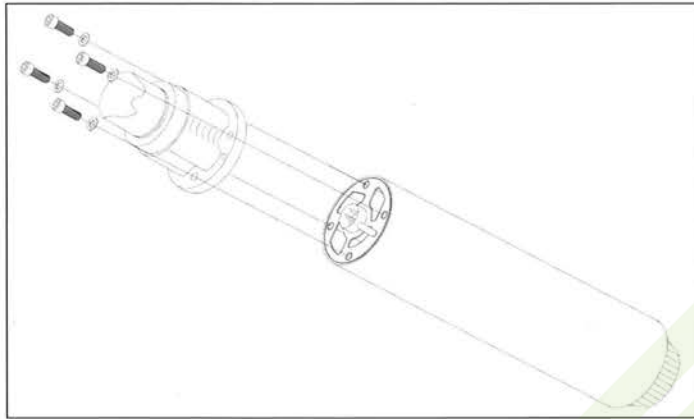

Figure 18 Remove the FSP

3. Rock the unit while pulling away from the discharge head until it is free.
4. Replace the old gasket with a new one provided. Place the new gasket on the new FSP so that all the holes align. (see Figure 19)

CAUTION! Gaskets from competitive FSPs will not seal properly and performance will be reduced.

5. Visually inspect the pigtail connector in the discharge head . replace if damaged. Be certain the indexing tab of the pigtail is seated in the notch of the discharge head.

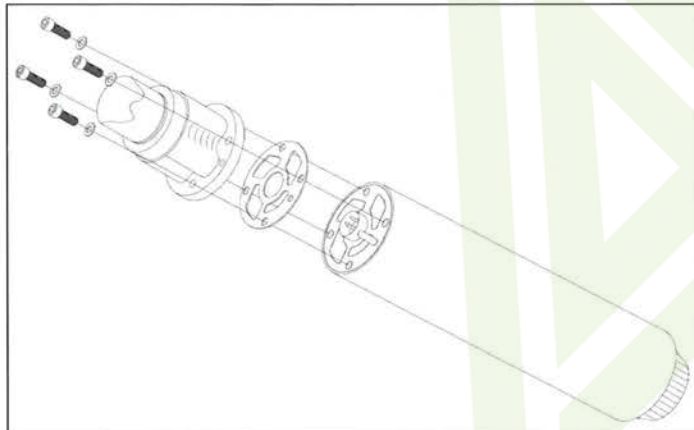

Figure 19 Replacing the gasket

6. Pull the pigtail connector in the discharge head out far enough to see the O-ring in the sidewall of its socket. Remove the connector's o-ring from the connector's socket and discard it. Get a ID 28*3.55 O-ring from the kit and lubricate it with petroleum jelly. Slide the new o-ring over the pigtail connector and push it in the groove in the wall of the connector's socket. Lubricate the pigtail connector body with petroleum jelly and push it back into its socket, making sure its index tab is in the socket's notch.

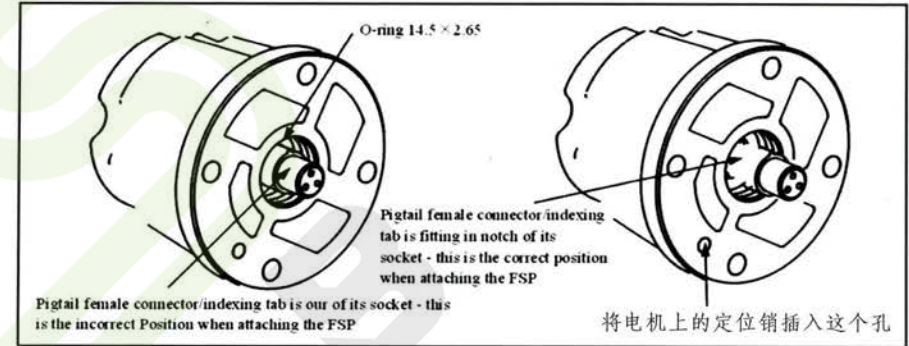

Figure 20 Verify pigtail's female connector is seated properly

7. Lubricate o-ring and pigtail with petroleum jelly.
8. Align the FSP position dowel and boss with the proper holes in the discharge head and push the FSP into position using hand force only.
The FSP should be snug against the discharge head prior to installing the FSP retaining bolts.
NOTICE: Use hand force to put the FSP onto the discharge head. If the FSP does not seat properly, snug against the discharge head, remove the FSP and correct the problem.
Do not use the bolts to pull the FSP into position. Use the cross pattern to snug and torque bolts. Do not over torque the bolts. Not following these instruction may cause parts to fail,
9. Install the four FSP retaining bolts and lock washers. Snug and then torque the bolts using a cross pattern technique. Torque to 7 f-lb (11N•m).
10. Replace the packer o-ring and the discharge o-ring seals after lubricating them with petroleum jelly.
11. Re-install the extractable portion into the tank using the steps previously described under "Installing the Pump" on page 10.
NOTICE: Before replacing the extractable, make sure that the surface of the packer o-ring and the discharge o-ring seals are clean
12. Refer to section entitled "Testing The Installation" on Page 18.
13. If applicable, open the ball valve down line from the pump.

10.3 Replacing the Functional Element

DANGER! Always disconnect, lock out, and tag the power before starting to service the pump.

When service unit use non sparking tools and use caution when removing or installing equipment to avoid generating a spark.

Disable the Pump

1. If a ball valve is installed down line from the pump, close it.
2. Back out the electrical connector disconnect bolt (see Figure 21)

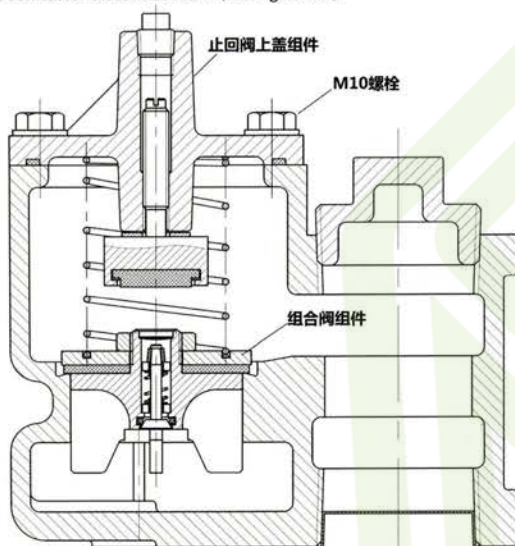

Figure 21 Packer with Functional Element

3. Swing the electrical connector aside.
4. To relieve the pressure, back out Functional Element screw (see Figure 14 on page 16), or remove the two lock-down bolts and rock the pump to allow excess pressure to flow into the tank.

Replace the Functional Element

1. Disconnect the siphon tubing (if siphon is installed)
2. Remove the two 3/8 inch bolts.

3. Carefully lift the Functional Element and remove it from the packer. The old check valve and spring will be resting inside the packer.

NOTE: The check valve and spring should be replaced if they are damaged or worn.

4. Be certain all mating surfaces are clean. Install new Functional Element O-rings, lubricated with petroleum jelly, on Functional Element (see Figure 25 on page 26). Carefully set the new Functional Element in place, then, replace the two M10 bolts and torque to 20-35 ft-lb (27-50N*m).
5. Check the seating pressure of the adjustable Functional Element for proper setting.
6. If applicable, open ball valve down line from the pump.

10.4 Replacing the Capacitor in Packer

DANGER! Always disconnect, lock out, and tag the power before starting to service the pump.

When service unit use non-sparking tools and use caution when removing or installing equipment to avoid generating a spark.

Serious injury or death can result from using a generic type capacitor. Generic-type capacitors do not contain internal bleed resistors.

NOTICE!

Capacitor is 450V, 25 μ F continuous duty with internal bleed resistor for 3/4 and 1-1/2 HP models.

Capacitor is 450V, 40 μ F continuous duty with internal bleed resistor for 1-1/2 HP models

1. Remove wiring compartment cover.
2. Remove retaining clip.
3. Pull out capacitor.
4. Pull quick connectors
5. Push connectors onto new capacitor.
6. Push capacitor into wiring compartment. Clip into place.
7. Lubricate capacitor cover o-ring with petroleum jelly and re-install cover. Do not use thread sealant. Torque to 35ft lb (50N*m).

10.5 Installing a Replacement Extractable Pump

DANGER! Always disconnect, lock out, and tag the power before starting to service the pump.

When service unit use non-sparking tools and use caution when removing or installing equipment to avoid generating a spark.

IF FIXED LENGTH, SKIP TO STEP9.

1. If a ball valve is installed down line from the pump, close it.
2. Remove existing JIAHAO's submersible pump. . see "Removing the Pump" on page 20

NOTE: Confirm length of pump prior to installation

CAUTION! Do not damage the surface above the discharge port. The O-ring below the leak detector port seals on this surface.

3. Attach the FSP (see "Attaching the FSP" on page 9)
4. Measure the distance from the bottom of the tank to the sealing surface on the manifold.
5. Uncoil pigtail and lay flat so it will feed into the packer without knotting or kinking.
6. Loosen the clinch assembly starting by unscrewing the set screw in the side of locking nut, then backing off the locking nut.
7. NOTE: A slight twisting of the FSP will loosen the seals and facilitate adjusting it to the correct length.

WARNING! Do not rotate piping beyond 1/4 turn.

8. Pull the FSP end until the distance between the packer O-ring seal and the bottom of the FSP is 8 inches (200mm) (14 inches (356mm) for floating suction) shorter than the distance measured in Step 4.

Take care not to damage the pigtail. If pump is to be adjusted shorter, tension must be kept on the pigtail to eliminate kinking.

9. Tighten the column pipe locking nut and torque to 30-35 in-lb (3.5-4N·m)
10. Attach tubing to barbed fitting, secure with clamp.

NOTE: Return line should be installed on every application to reduce nuisance trips of electronic tank monitoring.

11. Lay the return line tubing beside the column pipe. Stop 1.3 inch (32.5-7.6mm) above the discharge head.
12. Secure the return line tubing to the column pipe with tie straps. Locate the tie straps approximately 6 inches from packer, 6 inches from the discharge head, and in the middle of the tubing.

WARNING! For fixed length pumps:

If removed, install eyebolt plug, using an adequate amount of flesh, UL classified for petroleum, non setting thread sealant and torque to 50 ft-lbs (70N·m). Confirm that the lifting eyebolts is properly torqued to 10 ft-lbs (13.6N·m) with a minimum of 6 full threads installed. Occasionally, eyebolts are removed after pump installation and corrosion may occur in the threaded areas of the wiring compartment cover (eyebolt plug) and the eyebolt. If corrosion has, the cover and eyebolt should be replaced.

Utilize the lifting eyebolt to suspend the pump vertically and then install the pump into the manifold per Step 18.

13. Remove cover from wiring compartment.
14. Pull pigtail wires into wiring compartment.
15. Cut pigtail wires leaving approximately 8 inches (200mm) hanging out of wiring compartment.
16. Strip insulation off all wires 3/8 inch (10mm).

17. Using supplied wire nuts attach like colored pump pigtail wires to like colored electrical connector wires as shown in Figure 22.

18. Install excess wire into wiring compartment. Replace wiring compartment cover. Torque to 35 ft-lb (50N·m).

Thread sealant should not be used.

19. Install the pump into the manifold.

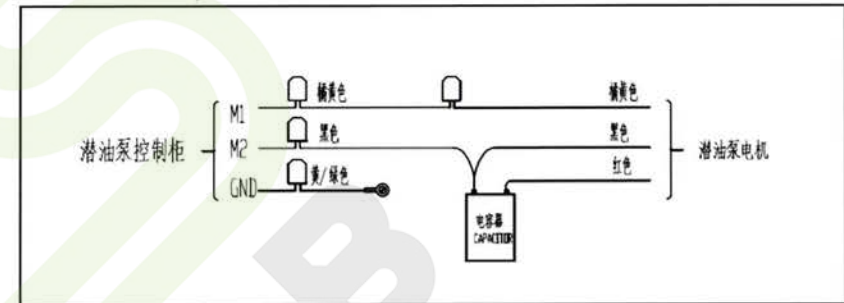

Figure 22 Wiring schematic

20. Align the positioning dowels of the manifold with the holes in the packer.
 21. Push the packer as far as possible against the manifold.
 22. Insert the lock-down bolts and torque to 45-55 ft lb (61-75N·m)
 23. Loosen the bolts that hold the conduit box to the manifold. Do not remove.
 24. Swing the electrical connector into position.
 25. Torque the electrical connector bolt to 25-50 ft-lb (34-68N·m)
 26. Torque the conduit box bolts to 30-45 ftlb (40-61N·m).
- NOTE: suggested tools (non-sparking) include a 3/4" wrench, 1/4" all en wrench, 9/16" wrench, screw driver, wire cutter and wire stripper.**
27. If applicable, open ball valve down line from the pump.
 28. After the installation is completed and tests have been made, purge system of air by pumping at least 15gallons (57 liters) through each dispenser, Begin with the dispenser furthest from the pump and work toward the pump.

11. Parts Lists

Customer Service

After unpacking the equipment, please inspect the parts. Make sure all accessories are included and that no damage occurred during shipping. Report any damage to the shipper immediately and inform a customer service representative.

12. 1 Assembly and Conduit Box Parts

Item #	Part #	Description	Qty
1	400125001	3/16 x 1 5/8 Spiral Pin	1
2	400615001	Manual Relief Plug	1
3	400211114	"O" - Ring, Plug	1
4	400627001	Retaining Ring	1
5	400616001	Manual Relief Screw	1
6	400333012	"O" - Ring, Relief Screw Top	1
7	400333007	"O" - Ring, Relief Screw Bottom	1
8	400628901	Manual Relief Plug Assembly	1
9	400629901	Manual Relief Screw Assembly	1
10	400259001	1/4 NPT Pipe Plug (may purchase locally)	3
11	400137930	Syphon Check Valve	1
12	400221930	Discharge Manifold (includes items 1, 8, 9, & 10)	1
13	151213930	Lead Assembly 156" Length	1
	151213932	Lead Assembly 240" Length	1
14		Purchase Locally Stationary Vapor Tube 3/8 OD x .035 Wall	1
15	4001689XX	Riser 4 1/2 OD x .188 Wall Steel Tubing (XX = length)	1
16		Purchase Locally 1/2 Steel Banding	2
17	400600001	5/16-24 x 7/16 Set Screw for VL units only	1
18	400333015	"O" - Ring, Motor Discharge	1
19	400264009	5/16-18 x 1 1/8 Socket Head Cap Screw (may purchase locally)	4
20	400263004	5/16 High-collar Lock Washer (may purchase locally)	4
21	402449001	Gasket, PMA	1
22	PMAXXX	Pump Motor Assembly (XXX indicates options & HP)	1
24	400981001	3/8-16 x 1 Hex Head Screw (may purchase locally)	2
25	400285002	3/8 Standard Lockwasher (may purchase locally)	2
26	400197930	Cover, Manifold Assembly	1
27	400211238	"O" - Ring	1
	400333238	"O" - Ring (A/G compatible)	1
28	400254001	Star Lock Washer	1
29	400147930	Valve, Clamp Assembly	1
30	400174930	Spring, Check Valve	1
31	400268001	Nut, Hex	1
32	400155003	Washer, Discharge Valve	1
33	400154101	Disc, Discharge Valve	1
34	400988931	Check Valve, Standard	1
	400988932	Check Valve, Model R	1
	400988933	Check Valve, Model W	1
	402459931	Check Valve, Model 65 PSI	1

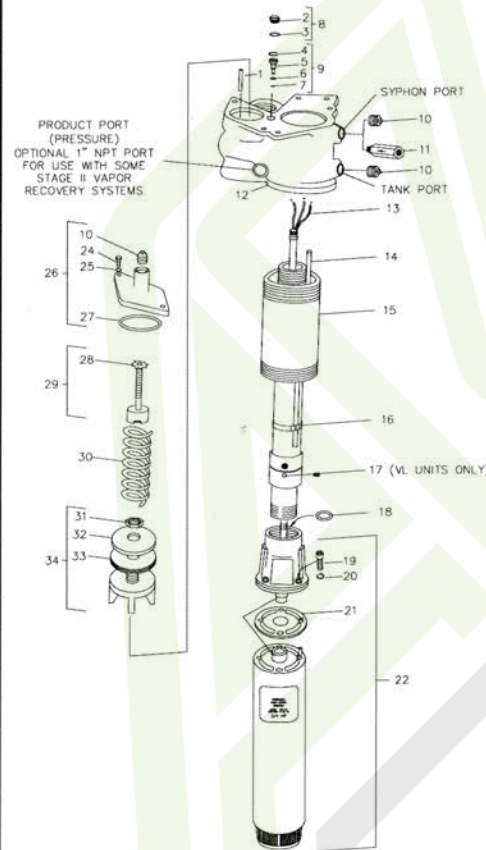

11. 2Packer-Manifold Assembly Parts

Item #	Part #	Description	Qty
1	400192930	Cover, Junction Box (includes item #2)	1
2	400210233	"O" - Ring	1
3	400655001	Boot, Capacitor	1
4	400170931	Capacitor Assembly 60Hz, 15µF, 380V 1Ø	1
	400170933	Capacitor Assembly 50Hz, 15µF, 440V 1Ø	1
	400170934	Capacitor Assembly 60 Hz, 40 µF, 370 V 1Ø	1
	N/A	Not Required for 3Ø units including IST/VS2	0
5	400236903	Plug, Contractors	1
6	400257001	Retaining Ring	1
7	400258002	3/8-16 x 1 1/4 Hex Head Bolt, (may purchase locally)	4
8	400285002	3/8 Standard Lock-washer (may purchase locally)	4
9	400280001	3/8 Standard Flat washer (may purchase locally)	2
10	400651930	Junction Box Assembly (includes 2 Item #7, #8, & #9)	1
11	400210212	"O" Ring	2
12	400258003	1/2-13 x 2 1/2 Hex Head Bolt (Part of Item #13)	1

Item #	Part #	Description	Qty
13	400200930	Wire Connector Kit (includes male/female connectors, (2) Item #11, (1) each Item #6, #12, & #20)	1
14	400589930	Cover (includes item #15)	1
15	400211229	"O" Ring	1
16	400236903	Plug, Contractors	1
17	400259002	3/8 NPT Pipe Plug (may purchase locally)	1
18	400562901	Syphon Jet Assembly	1
19	400211046	"O" Ring	1
20	400249001	Retaining Ring	1
22	400250002	1/8 Dia. x 1/2 Roll Pin	1
23	400211343	"O" Ring	2
	400333343	"O" Ring (A/G compatible)	2
24	400211340	"O" Ring	1
	400333340	"O" Ring (A/G compatible)	1
25	400259005	2NPT SQ Head Plug	1

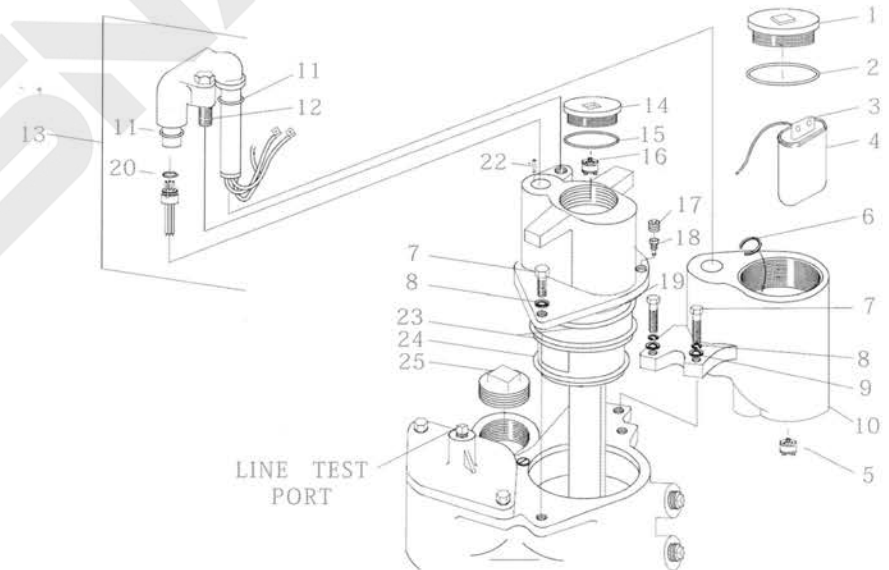

11.3 Control Box

The submersible pump must be used together with a dedicated explosion-proof electrical control box, or matched with an electrical control box made according to the following requirements: set the overvoltage protection value at +10% of the rated voltage, and -10% is the undervoltage protection value; Set the overcurrent protection value at +10% of the rated current, and set the undercurrent protection value at -15%; And equipped with short circuit, overload, dry running, liquid level control and other protections.

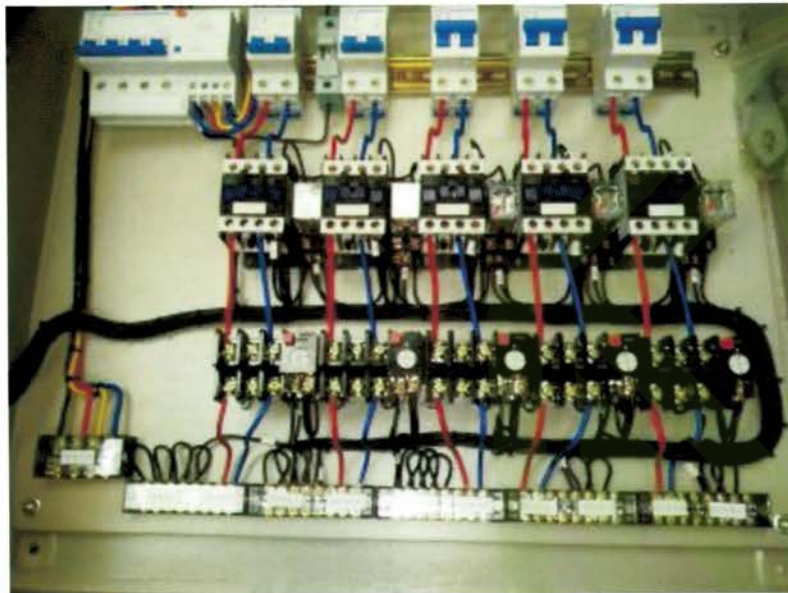

Figure 27 Control Box

Table 9 Control Box W/220V Coil (50Hz)

No.	Part No.	Describe	Qty
1	/	Control Box	1
2	/	Pilot light Assembly	1
3	/	Line contractor relay	1
4	/	Toggle Switch	1
5	/	Terminal block	1

Table 10 Control Box W/380V Coil (50Hz)

No.	Part No.	Describe	Qty
1	/	Control Box	1
2	/	Pilot light Assembly	1
3	/	Line contractor relay	1
4	/	Toggle Switch	1
5	/	Terminal block	1

11.4 Functional Application of Pump Siphon

After equipped with siphon assy JIAHAO submersible pump can complete the connection between single fuel with mutiple tanks.

After equipped with siphon assy JIAHAO submersible pump can complete the connection between single fuel with mutiple tanks.

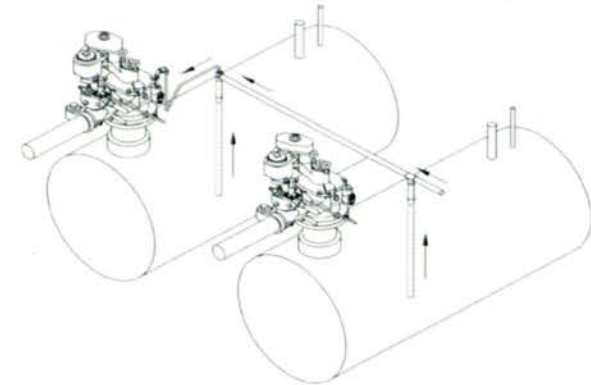

12 Submersible Pump Installation Examples

12. 1 Pump Installation



12. 2 stand tube Installation



12. 3 Telescope length setting

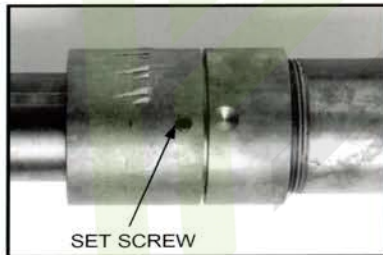
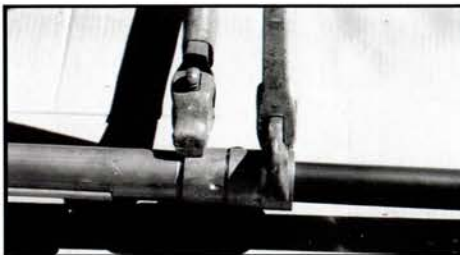

12. 4 lining

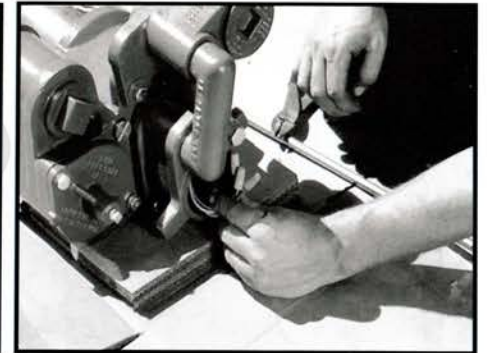

APPENDIXC: JH-LQB Submersible Pumps Safety Instruction

Approved by the explosion protection class, submersible pumps must be marked with the following information:

Explosion proof mark: Ex db sa IIB T4 Ga/Gb

- All submerged turbine pumps, manifolds and associated equipment shall be installed in accordance with the manufacturer's installation, operation and service manuals supplied.
- All installations shall provide reliable electrical connection between the pump/motor, frame, pipe, manifold or junction box and the tank structure for the electrical protection and equipotential bonding.
- The minimum fuel level shall be set 30mm above the highest product intake level at the bottom of the pump motor.
- Where terminal boxes are used for termination of the cable from the motor and the supply source, they shall be ATEX Certified for use in gas group IIA and category 2.
- Where a differential pressure switch or transducer is installed, each must be capable of ensuring that the nominated temperature classification is not exceeded.
- Fasteners are non metric. They shall be replaced only by identical fasteners.
- The installation guide manual can be seen as a technical guidance document.